

BCB

BAR CONVENT BERLIN

City Life Spirits

INTERNATIONAL
BAR AND BEVERAGE
TRADE SHOW

11 – 13 OCTOBER

2021

SALES KIT



BCB

Berlin – pulsating metropolis and trendsetting city, a melting pot for so many different cultures and lifestyles.

In 2021, Bar Convent Berlin is going to recreate the German capital's urban lifestyle mix in the city's exhibition centre.

For BCB, the age of City Life Spirits begins with a move to Berlin Messe. Our new location means that there will be more space available for creativity, stands, presentations and networking. The core values of BCB, however, will remain unchanged – it will continue to be authentic, international, and focus on the premium segments and top education. As always, the BCB team will be there to benefit exhibitors and visitors alike. It is our common goal, to provide the perfect setting for exchanging and promoting ideas – whether you are a bartender, bar-owner, distributor, hotel, F&B manager, drinks company or other service-provider in the industry.

BCB – an urban take on life

The new BCB concept, City Life Spirits, will become an integral part of the fair's architecture, content and interaction, by providing a common thread for the event. Every hall will be brought to life by hot spots and special events reflecting different city trends. Bar Convent Berlin will become an urban market, a French bistro or community bar, also offering co-working spaces, a rooftop bar and the BCB Lab. The transit areas between different halls will become upbeat cross-cultural crossing points, enlivened by late-night stores, coffee stations, exhibitions or musical acts. As exhibitor, you have the choice of joining in with this world or going off and doing your own thing if you prefer. BCB offers a wealth of creative solutions and opportunities to get involved – aside from the classic stands – to give smaller brands their own particular platform too.

BCB offers new benefits

In the matter of a few years, Bar Convent Berlin has grown from being a small get-together for the industry to become of the most important trade fairs of the international bar world. Moving to a new location means we can open our doors to an ever-growing number of interested trade visitors. You, as exhibitor, benefit from a better infrastructure, services, and have far greater opportunities to do your own thing and enjoy a successful trade fair.

BE YOURSELF. BE BERLIN.

City Life Spirits



BCB

OPENING HOURS/ LOCATION

OPENING HOURS

Monday, 11.10.21, 11 a.m. – 7 p.m.

Tuesday, 12.10.21, 11 a.m. – 7 p.m.

Wednesday, 13.10.21, 11 a.m. – 6 p.m.

ORGANISER

Reed Exhibitions Deutschland GmbH

Völklinger Str. 4

40219 Düsseldorf

Telephone +49 211 90191-349

Telefax +49 211 90191-244

www.barconvent.com

LOCATION

Exhibition Centre Berlin

North Entrance

Hammarskjöldplatz

14057 Berlin

www.messe-berlin.de

DURATION

3 days

FREQUENCY

Annually

EXHIBITORS

500

BRANDS

1,400

ANTICIPATED VISITORS

18,000



SITE PLAN

BCB IN NUMBERS*

TRADE VISITORS IN 2019

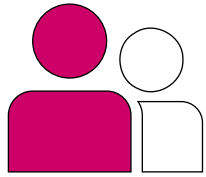

15,162

Trade visitors from 92 different countries

MAIN INTERESTS VISITORS 2019

in comparison to 2018

95% 92%

Spirits

20% 12%

Wine

49% 37%

Fillers & Softdrinks

20% 18%

Services & Consulting

40% 39%

Equipment & Bar Supplies

13% 12%

Literature & Media

23% 19%

Kaffee & Tee & Heißgetränke

12% 8%

Cider

22% 19%

Craft Beer

11% 6%

Snacks

21% 13%

Sparkling Wine

4% 3%

Tobacco

20% 19%

Beer

VISITORS ORIGIN 2019



44%

Germany

2.1%

Italy

3.6%

Great Britain

2%

Austria

2.6%

Poland

0.8%

USA

2.2%

Russia

26%

Other european

2.2%

Switzerland

2.2%

Non european

HOTSPOTS & BUY-INS



HALL 19 BCB Community

Hotspot:
Community Bar



PALAIS Bistro

Hotspot:
Sparkling & Food
Pairing & BCB Shop &
Co-Working



HALL 18 Urban Gardening

Hotspot:
Urban Gardening & Rooftop



HALL 17 Quality Time

Hotspot:
Coffee Bar



HALL 15.1 Urban Market

Hotspot:
Young Guns

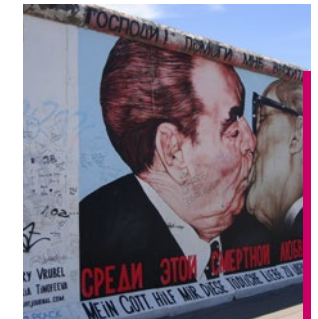

HALLE 14.1 Art/Street Art

Hotspot:
Art Gallery



HALL 12 Senses

Hotspot:
Experience of Senses



HALL 11.1 Metropolis at Night

Hotspot:
Secret Club



TRANSIT AREA The official BCB kiosk

Hotspot:
Späti



YOUR IDEAS ???

We look forward to hearing any new stories you have to tell or any new formats you would like us to help you realise.



"In our industry the month of October has become synonymous with peak networking, business initiation and the launch of new products. It's great to see BCB going from strength to strength and expanding internationally."

HELMUT ADAM (Co-founder BCB & CEO Mixology Publishing)

"Since BCB moved to Station Berlin, I've considered the palais.Berlin area and it's beautiful surroundings as the only realistic next venue for the fair. It's amazing to see this happen in 2021."

JENS HASENBEIN (Co-founder BCB & CFO Mixology Publishing)

INDIVIDUAL STAND SPACE

Stand space can be booked individually. This option is ideal for exhibitors who have a bar or exhibition furniture or would like to have their own stand built to order. If required, extra back and side walls can be ordered through the Online Service Centre at **55 EUR** per running metre.

Display area as from 6sqm:	602 EUR/sqm
Incidental costs:	35.00 EUR/sqm incl. the standard exhibitor's communications package, waste disposal during the exhibition and a logistics fee
AUMA charge:	0.60 EUR/sqm
Insurance:	310.00 EUR

It is not permitted to bring your own glasses.

NEW:

Exhibitors are responsible for disposing of any waste arising from the construction, stand-time and tear-down of their stand / exhibition area in a proper and environment-friendly manner.

You will be provided with the appropriate bin bags for disposing of waste correctly throughout the duration of the fair.

Disposal during assembly and dismantling must be ordered in advance from the Online Service Center for a fee.

Waste disposal during the term is only then covered by the maintenance fee, if you put your waste properly into the designated waste bags
dispose of.

BCB staff will pick up the sorted waste bags from your stand.

If there is no independent sorting of the waste into the bin bags, you will be invoiced for the additional costs incurred after the exhibition.

Prices are net plus the statutory VAT

SYSTEM STAND CONSTRUCTION*

You can book the System Stand Construction through our Online Service Centre

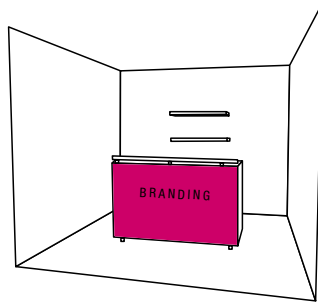

BASIC ROW STAND

For exhibitor space (row stands only) as from 6 sqm: **179 EUR/sqm**

- Features:
- Wooden walls made of white KS 19 mm mounted in U profiles, height 2.5m
 - 2x shelf for counterfeit mirror
 - 3x display floodlights
 - Carpet Rips B1 gray
 - 1x counter (BHT 160x110x80) with branding (foil inlay)
 - 1x exhibitor name (foil cut)
 - 1x triple socket
 - 1x waste bin

Service: Incl. Assembly and disassembly and transport to the fair

*Design and final price depend of the rented individual area.

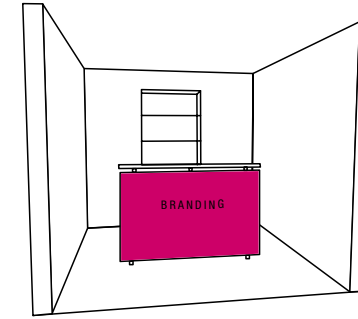

PREMIUM ROW STAND

For exhibitor space (row stands only) as from 6 sqm: **339 EUR/sqm**

- Features:
- Pre-hung wooden walls on a frame construction KS white, height 2.5m
 - 1x suspended wooden wall on a frame construction KS with internal shelves
 - 3x display floodlights
 - PVC in wood look
 - 1x counter (BHT 160x110x80) with branding (foil inlay)
 - 1x exhibitor name (foil cut)
 - 1x triple socket
 - 1x waste bin

Service: Incl. Assembly and disassembly and transport to the fair

*Design and final price depend of the rented individual area.

Prices are net plus the statutory VAT

ONE BRAND STAND

1 stand – 1 brand

The One Brand Stand is the perfect complete package for presenting a single brand or products which are sold under a single brand name.

Exhibitor space
approx. 2m x 2.5m: **2,900 EUR**

Features: 1 bar and back buffet incl. logo branding*

Services: Power point incl. 1 socket

Plastic degustation beakers

Waste disposal during the fair

Standard exhibitor's communications package

Insurance

AUMA charge

exclusive flat rate charge for glasses**

Additional options bookable from the Online Service Centre:

Fridge/freezer approx. 110 EUR

Logo branding on bar approx. 150 EUR

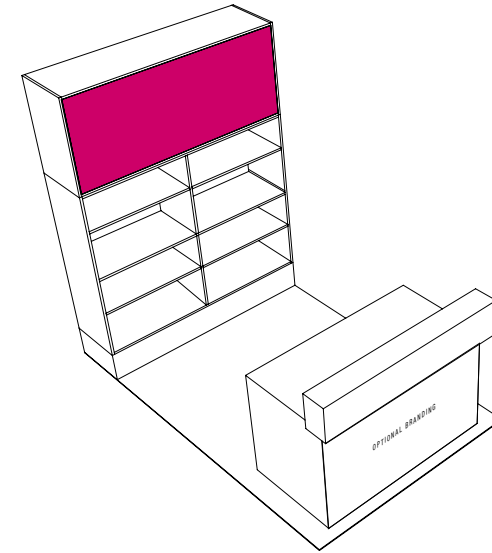

*It is not permitted to apply your own branding.

**For logistical reasons, it is not permitted to bring your own glasses

NEW:

Exhibitors are responsible for disposing of any waste arising from the construction, stand-time and tear-down of their stand / exhibition area in a proper and environment-friendly manner.

You will be provided with the appropriate bin bags for disposing of waste correctly throughout the duration of the fair. Disposal during assembly and dismantling must be ordered in advance from the Online Service Center for a fee.

Waste disposal during the term is only then covered by the maintenance fee, if you put your waste properly into the designated waste bags dispose of.

BCB staff will pick up the sorted waste bags from your stand.

If there is no independent sorting of the waste into the bin bags, you will be invoiced for the additional costs incurred after the exhibition.

Prices are net plus the statutory VAT

PORTFOLIO STAND

The Portfolio Stand is the perfect complete package for manufacturers and distributors wishing to present a range of brands.

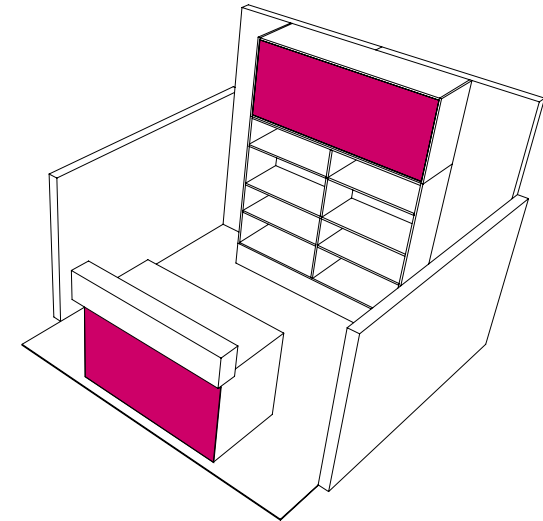

Exhibitor space
approx. 3m x 3m:

5,740 EUR

Features: 1 bar and back buffet incl. logo branding

Services: 2 bar stools

2 side walls

Power point incl. 1 socket

Plastic degustation beakers

Waste disposal during the fair

Standard exhibitor's communications package

Insurance

AUMA charge

exclusive flat rate charge for glasses**

Additional options bookable from the Online Service Centre:

Fridge/freezer approx. 110 EUR

*It is not permitted to apply your own branding.

**For logistical reasons, it is not permitted to bring your own glasses

NEW:

Exhibitors are responsible for disposing of any waste arising from the construction, stand-time and tear-down of their stand / exhibition area in a proper and environment-friendly manner.

You will be provided with the appropriate bin bags for disposing of waste correctly throughout the duration of the fair. Disposal during assembly and dismantling must be ordered in advance from the Online Service Center for a fee.

Waste disposal during the term is only then covered by the maintenance fee, if you put your waste properly into the designated waste bags dispose of.

BCB staff will pick up the sorted waste bags from your stand.

If there is no independent sorting of the waste into the bin bags, you will be invoiced for the additional costs incurred after the exhibition.

Prices are net plus the statutory VAT

COFFEE

INDIVIDUAL STAND SPACE

The actual location is determined by the event organizer. This type of stand is suitable for exhibitors who already possess a bar or exhibition furniture. If required, rear and side walls can be booked via the Online Service Centre at a cost of **55 EUR** per running metre.

Exhibitor space approx. 6sqm:	485 EUR/sqm
Location:	within Coffee Area
Incidental costs:	35.00 EUR/sqm incl. standard exhibitor's communications package, waste disposal during the fair Exclusive flat rate charge for glasses*
AUMA charge:	0.60 EUR/sqm
Insurance:	310.00 EUR

*For logistical reasons, it is not permitted to bring your own glasses.

NEW:

Exhibitors are responsible for disposing of any waste arising from the construction, stand-time and tear-down of their stand / exhibition area in a proper and environment-friendly manner.

You will be provided with the appropriate bin bags for disposing of waste correctly throughout the duration of the fair. Disposal during assembly and dismantling must be ordered in advance from the Online Service Center for a fee.

Waste disposal during the term is only then covered by the maintenance fee, if you put your waste properly into the designated waste bags dispose of.

BCB staff will pick up the sorted waste bags from your stand.

If there is no independent sorting of the waste into the bin bags, you will be invoiced for the additional costs incurred after the exhibition.

Prices are net plus the statutory VAT

COFFEE

ROASTED COFFEE STAND

The Roasted Coffee Stand presents the perfect opportunity for smaller roasting houses to present their wares.

Exhibitor space

approx. 2m x 2m: **1,220 EUR**

Features: 1 bar and 1 rear wall with shelf (branding inclusive)

Services: Power point incl. 1 socket

Waste disposal during the fair

Standard exhibitor's communications package

Insurance

AUMA charge

exklusive Gläserpauschale*

Additional options bookable from the Online Service Centre:

Fridge/freezer approx. 110 EUR

High voltage power: price available on request

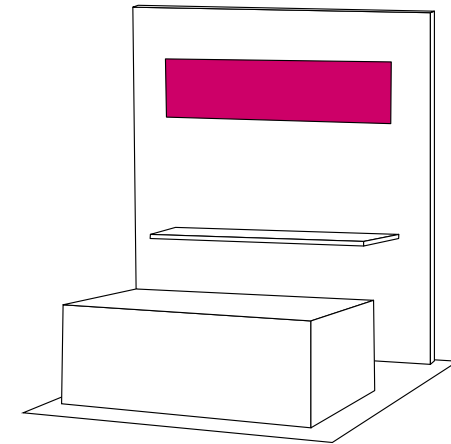

*For logistical reasons, it is not permitted to bring your own glasses

NEW:

Exhibitors are responsible for disposing of any waste arising from the construction, stand-time and tear-down of their stand / exhibition area in a proper and environment-friendly manner.

You will be provided with the appropriate bin bags for disposing of waste correctly throughout the duration of the fair. Disposal during assembly and dismantling must be ordered in advance from the Online Service Center for a fee.

Waste disposal during the term is only then covered by the maintenance fee, if you put your waste properly into the designated waste bags dispose of.

BCB staff will pick up the sorted waste bags from your stand.

If there is no independent sorting of the waste into the bin bags, you will be invoiced for the additional costs incurred after the exhibition.

Prices are net plus the statutory VAT

BEER

INDIVIDUAL STAND SPACE

Stand space can be booked individually. This option is ideal for exhibitors who have a bar or exhibition furniture or would like to have their own stand built to order. If required, extra back and side walls can be ordered through the Online Service Centre at **55 EUR** per running metre.

Price:	485 EUR/sqm
Location:	within Beer Area
Incidental costs:	35.00 EUR/sqm incl. standard exhibitor's communications package, waste disposal during the fair Exclusive flat rate charge for glasses*
AUMA charge:	0.60 EUR/sqm
Insurance:	310.00 EUR

*For logistical reasons, it is not permitted to bring your own glasses

NEW:

Exhibitors are responsible for disposing of any waste arising from the construction, stand-time and tear-down of their stand / exhibition area in a proper and environment-friendly manner.

You will be provided with the appropriate bin bags for disposing of waste correctly throughout the duration of the fair. Disposal during assembly and dismantling must be ordered in advance from the Online Service Center for a fee.

Waste disposal during the term is only then covered by the maintenance fee, if you put your waste properly into the designated waste bags dispose of.

BCB staff will pick up the sorted waste bags from your stand.

If there is no independent sorting of the waste into the bin bags, you will be invoiced for the additional costs incurred after the exhibition.

Prices are net plus the statutory VAT

BEER

DRAFT ALLEY STAND

Draft Alley was conceived exclusively for breweries and smaller start-ups. Inspired by the community thought behind the beer scene, suppliers of different brands will be appearing here, cheek by jowl. This enables the trade visitor to get to know a wealth of different beer types and producers over just a few metres. The principle behind Draft Alley is that each stand is devoted to the beers brewed by a single brand.

Exhibitor space approx. 2m x 2m:	1,220 EUR
Features:	1 bar, 1 rear wall and 1 fridge
Services:	Power point incl. 1 socket Waste disposal during the fair Standard exhibitor's communications package Insurance AUMA charge exclusive flat rate charge for glasses*

Additional options bookable from the Online Service Centre:

Logo branding on front of bar approx. 150 EUR

Fridge/freezer approx. 110 EUR

High voltage power: price available on request

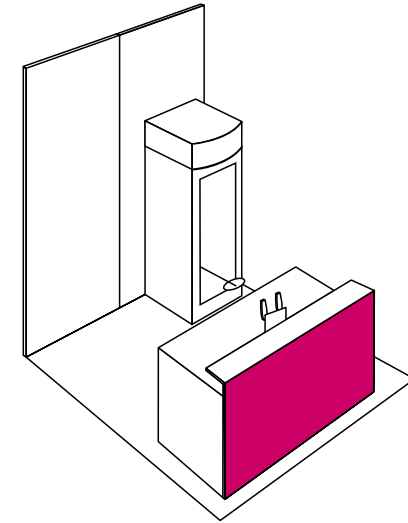

*For logistical reasons, it is not permitted to bring your own glasses

NEW:

Exhibitors are responsible for disposing of any waste arising from the construction, stand-time and tear-down of their stand / exhibition area in a proper and environment-friendly manner.

You will be provided with the appropriate bin bags for disposing of waste correctly throughout the duration of the fair. Disposal during assembly and dismantling must be ordered in advance from the Online Service Center for a fee.

Waste disposal during the term is only then covered by the maintenance fee, if you put your waste properly into the designated waste bags dispose of.

BCB staff will pick up the sorted waste bags from your stand.

If there is no independent sorting of the waste into the bin bags, you will be invoiced for the additional costs incurred after the exhibition.

Prices are net plus the statutory VAT

SPARKLING

INDIVIDUAL STAND SPACE

Stand space can be booked individually. This option is ideal for exhibitors who have a bar or exhibition furniture or would like to have their own stand built to order. If required, extra back and side walls can be ordered through the Online Service Centre at **55 EUR** per running metre.

Price:	602 EUR/sqm
Location:	Actual site within the Sparkling section may vary
Incidental costs:	35.00 EUR/sqm incl. standard exhibitor's communications package, waste disposal during the fair exclusive flat rate charge for glasses*
AUMA charge:	0.60 EUR/sqm
Insurance:	310.00 EUR

It is permitted to sell samples at a small charge.

*For logistical reasons, it is not permitted to bring your own glasses

NEW:

Exhibitors are responsible for disposing of any waste arising from the construction, stand-time and tear-down of their stand / exhibition area in a proper and environment-friendly manner.

You will be provided with the appropriate bin bags for disposing of waste correctly throughout the duration of the fair. Disposal during assembly and dismantling must be ordered in advance from the Online Service Center for a fee.

Waste disposal during the term is only then covered by the maintenance fee, if you put your waste properly into the designated waste bags dispose of.

BCB staff will pick up the sorted waste bags from your stand.

If there is no independent sorting of the waste into the bin bags, you will be invoiced for the additional costs incurred after the exhibition.

Prices are net plus the statutory VAT

SPARKLING

SPARKLING PACKAGE STAND

The Sparkling Package Stand provides the perfect opportunity for presenting sparkling wines as part of an appealing joint stand featuring several manufacturers.

Exhibitor space
approx. 2m x 2m

3,500 EUR

Location: Actual site within the Sparkling section may vary

Features: 1 bar, 1 rear buffet incl. logo branding, 1 fridge

Service: Power point incl. 1 socket

Waste disposal during the fair

Standard exhibitor's communications package

Insurance

AUMA charge

exclusive flat rate charge for glasses*

It is permitted to sell samples at a small charge.

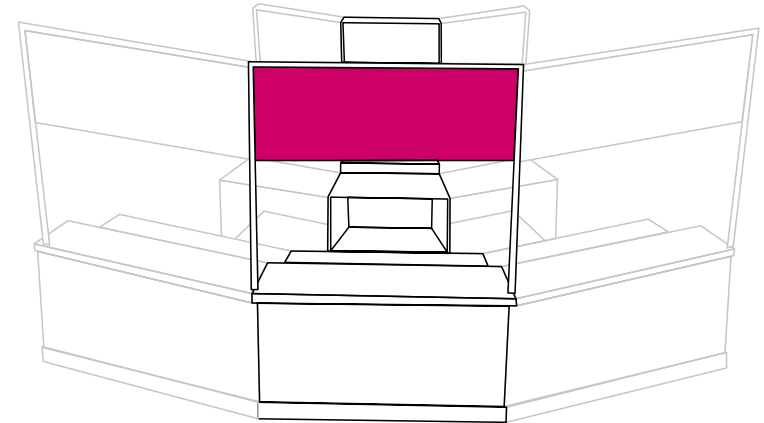

*For logistical reasons, it is not permitted to bring your own glasses

NEW:

Exhibitors are responsible for disposing of any waste arising from the construction, stand-time and tear-down of their stand / exhibition area in a proper and environment-friendly manner.

You will be provided with the appropriate bin bags for disposing of waste correctly throughout the duration of the fair. Disposal during assembly and dismantling must be ordered in advance from the Online Service Center for a fee.

Waste disposal during the term is only then covered by the maintenance fee, if you put your waste properly into the designated waste bags dispose of.

BCB staff will pick up the sorted waste bags from your stand.

If there is no independent sorting of the waste into the bin bags, you will be invoiced for the additional costs incurred after the exhibition.

Prices are net plus the statutory VAT

YOUNG GUNS

PACKAGE STAND

The perfect solution for manufactures and small firms with innovative and high quality products in the spirit, filler and equipment segment. Please, be aware of the eligibility requirements.

Exhibitor space
approx. 2m x 2.5m: **2,400 EUR**

Location: Actual site within hall 15 may vary

Features: 1 market stall

Services: Power point incl. 1 socket
Plastic degustation beakers
Waste disposal during the fair
Standard exhibitor's communications package
Insurance
AUMA charge

exclusive flat rate charge for glasses*

ELIGIBILITY REQUIREMENTS:

- a new brand that has not been on sale for any longer than 3 years
(Wholesale listing or tax certificate for spirits required as proof)
- No publicized investment by a strategic partner
- No company may have more than 2 participants in the Young Guns Pavilion
- The decision on who is eligible lies with the BCB Jury

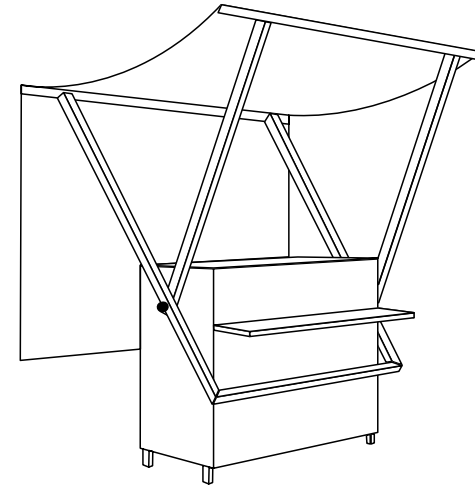

*For logistical reasons, it is not permitted to bring your own glasses

NEW:

Exhibitors are responsible for disposing of any waste arising from the construction, stand-time and tear-down of their stand / exhibition area in a proper and environment-friendly manner.

You will be provided with the appropriate bin bags for disposing of waste correctly throughout the duration of the fair. Disposal during assembly and dismantling must be ordered in advance from the Online Service Center for a fee.

Waste disposal during the term is only then covered by the maintenance fee, if you put your waste properly into the designated waste bags dispose of.

BCB staff will pick up the sorted waste bags from your stand.

If there is no independent sorting of the waste into the bin bags, you will be invoiced for the additional costs incurred after the exhibition.

Prices are net plus the statutory VAT

EXHIBITOR COMMUNICATION PACKAGES & SPONSORING SERVICES

MEDIA PACKAGE BASIC (M1)

- Listing in the **online list of exhibitors**
- Online **exhibitor profile incl. logo**, company description and contact details in the online exhibitor directory
- **Upload of product images & documents** in the online list of exhibitors
- Listing in the online exhibitor list
- Listing in the Print Show Guide
- Company description (500 characters) print
- **5 Product categories print**

99.00 EUR

MEDIA PACKAGE ADVANCED (M2)

- Listing in the **online list of exhibitors**
- Online **exhibitor profile incl. logo**, company description and contact details in the online exhibitor directory
- **Upload of product images & documents** in the online list of exhibitors
- Listing in the online exhibitor list
- Listing in the Print Show Guide
- Company description (500 characters) print
- **5 Product categories print**
- **Brand listings & product images** in the online exhibitor list
- **Contact details** in the online exhibitor list
- **Positioning of the listing at the beginning** of the exhibitor listing
- **Labelling Highlighting as "Premium"** listing in the inline exhibitor list
- **Logo in the hall directory print**
- **Colour highlighting** of the stand in the hall plan of the hall index **print**

810.00 EUR

MEDIA PACKAGE PREMIUM (M3)

- Listing in the **online list of exhibitors**
- Online **exhibitor profile incl. logo**, company description and contact details in the online exhibitor directory
- **Upload of product images & documents** in the online list of exhibitors
- Listing in the online exhibitor list
- Listing in the Print Show Guide
- Company description (500 characters) print
- **5 Product categories print**
- **Brand listings & product images** in the online exhibitor list
- **Contact details** in the online exhibitor list
- **Positioning of the listing at the beginning** of the exhibitor listing
- **Labelling Highlighting as „Premium“** listing in the inline exhibitor list
- **Logo in the hall directory print**
- **Colour highlighting** of the stand in the hall plan of the hall index **print**
- **Special listing** of your company feature **sponsoring of a product category**, feature **homepage carousel**
- **1 advertisement 4c print**

1,740.00 EUR

PRICE OVERVIEW 2021

Stand Space

Individual stand space BCB per sqm	602.00 EUR
Individual stand space Brew Berlin per sqm	485.00 EUR
Individual stand space Coffee Convent per sqm	485.00 EUR
Early Bird individual stand space BCB per sqm	585.00 EUR*
Early Bird individual stand space Brew Berlin per sqm	470.00 EUR*
Early Bird individual stand space Coffee Convent per sqm	470.00 EUR*

*Deadline Early Bird 31.12.2020

Packages (space plus stand construction)

One Brand Stand (2m x 2.50m)	2,900.00 EUR
Portfolio Stand (3m x 3m)	5,740.00 EUR
Coffee Roaster Stand (2m x 2m)	1,220.00 EUR
Draught Beer Stand (2m x 2m)	1,220.00 EUR
Package Stand (2m x 2m) Sparkling	3,500.00 EUR
Package Stand (2m x 2,5m) Young Guns	2,400.00 EUR

Potential additional services/costs

Back/side walls (2.50m high), reinforced, per sqm	55.00 EUR
Back/side walls custom-made	Price on request
Freezer flat rate charge	ca. 110.00 EUR

Glasses available separately via BOELS Webshop

Water connection

*Normal supply, 15mm/normal drainage 50mm

Incl. installation of a bar, combi kitchen or single/double sink as from 460.00 EUR

Power supply as from 201.00 EUR

*3,3 kW/16 A AC 230 V, with distribution

incl. 1 power point + 1 off-peak electricity power point

Waste Disposal (for assembly and disassembly)

Bin bags 120l (colour-coded):	
Paper/carboard	7.80 EUR per bin bag
Glass	7.80 EUR per bin bag
Plastic	7.80 EUR per bin bag
Residual waste	16.90 EUR per bin bag
Prices include disposal	

Incidental Costs for individual spaces

Maintenance	per sqm 35.00 EUR
Insurance cover charge for individual areas	310.00 EUR
Co-exhibitor charge incl. Insurance	550.00 EUR
Auma charge	per sqm 0.60 EUR

Exhibitor Media Communications Package

Media Package BASIC (M1)	99.00 EUR
Media Package ADVANCED (M2)	810.00 EUR
Media Package PREMIUM (M3)	1.740,00 EUR

Badges

Badges	34.00 EUR
--------	-----------

Prices are net plus the statutory VAT and subject to change

CONTACT & ADDRESSES

EVENT ORGANIZER

Reed Exhibitions Deutschland GmbH
Völklinger Str. 4
40219 Düsseldorf
Telephone +49 211 90191-197
Telefax +49 211 90191-244
www.barconvent.com

SITE OF EVENT

Exhibition Centre Berlin
North Entrance
Hammar skjöldplatz
14057 Berlin
www.messe-berlin.de

SALES

Anna Lena Grytz
Project Manager Sales
Telephone +49 211 90191-140
annalena.grytz@reedexpo.de

Thea König
Sales Manager
Telephone +49 211 90191-197
thea.koenig@reedexpo.de

Michaela Giesselmann
Sales Manager
Telephone +49 211 90191-240
michaela.giesselmann@reedexpo.de

INTERNATIONAL CONTACTS

ITALY

Elisa Limatola
+39 02 43517089
Elisa.limatola@reedexpo.it

SPAIN & PORTUGAL

Paz Jarque
+34 617 198 997
paz.jarque@thinkingabroad.com

FRANCE

Helga Quien
+33 1 79 71 96 13
hquein@reed-export.fr

BENELUX

Nadine Grotendorst
+33 1 79 71 93 08
Ngrotendorst@reed-export.fr

GREECE

Danae Margaritidi
+30 694 736 4289
dmargaritidi@beerbartender.gr

UNITED KINGDOM

Dean Cousins
+44 208 910 7155
dean.cousins@reedexpo.co.uk

LATIN AMERICA

Stephen Guthartz
+1 203 840 5336
sguthartz@reedexpo.com

USA

Katie Lind
+12038405423
klind@reedexpo.com

JAPAN

Ryotaro Kunishige
+81 362 612 996
kunishiger@reedexpo.co.jp

EASTERN EUROPE

Daniel Bart
+36 30 185 73 74
tonycaviar@gmail.com

KOREA

Hayoung Jang
+82 10 3550 0385
hayoung.jang@reedexhibitions.co.kr

POLAND

Mateusz Buczek
+48 535138138
kontakt@mateusz buczek.com.pl

BCB

BAR CONVENT BERLIN